

# Moon, Saturn & Venus

## Celestial Harmonious Design

Inspired by celestial bodies, our circular-designed product group-featuring the 'Moon, Saturn, and Venus' models-enhances acoustic balance in spaces.

These models, drawing from the natural geometries of planets, work harmoniously to optimize acoustics. Incorporating these design-focused pieces balances visual and auditory elements, creating an immersive and harmonious environment.



## Moon Sound-Absorbing Decorative Panel

300mm x 300mm x 13mm

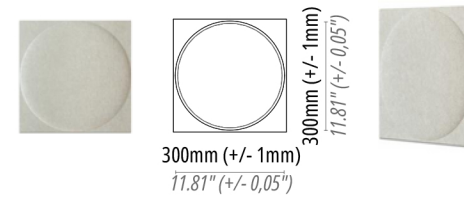

		Inherent Colors	Color-IT Colors	Peel & Stick (Optional)
<b>PRODUCT CODE / DESCRIPTION</b>	<b>Box Qty / m2</b>			
MON-20AAN - Inherent Colors (Panel Only)	48 / 4.32 m2			
MON-20PSN - Inherent Colors + Peel & Stick	48 / 4.32 m2			
MON-20AAC - Color-IT (Panel Only)	48 / 4.32 m2			
MON-20PSC - Color-IT + Peel & Stick	48 / 4.32 m2			

**APPLICATION**  
Wall & Ceiling - Indoor use only

**MATERIAL**  
Mechanical needled punch industrial felt.  
100% PET up to 60% Recycled content & Recyclable



Smooth Surface - Impact Resistance - Flexible

**FIRE RATING**  
A Class (ASTM E84) - B s1 d0 (EN 13501-1)

**THERMAL INSULATION**  
0,035 W/mK

**WEIGHT**  
1 tile: 112.5 gr. +/- 10% tolerance  
1 tile: 0.25 lbs with +/- 10% tolerance

**THICKNESS**

Max. 13 mm (+/- 2 mm) - 0.51" (+/-0.08")  
Min. 3 mm (+/- 2 mm) - 0.12" (+/-0.08")

**BOX SIZE & CONTENT**  
W: 620 mm D: 660 mm H: 190 mm  
W: 24.5" D: 26" H: 7.5"

1 Box: 48 x panels  
1 Box: 4.32 m2  
1 Box: 46.50 ft2

1 Color of choice per package  
Gross weight: 6.8 kg  
Gross weight: 15 lbs

### PALETTE SIZE & CONTENT

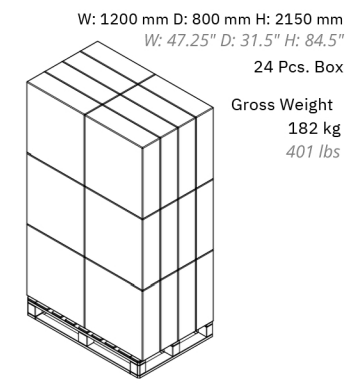
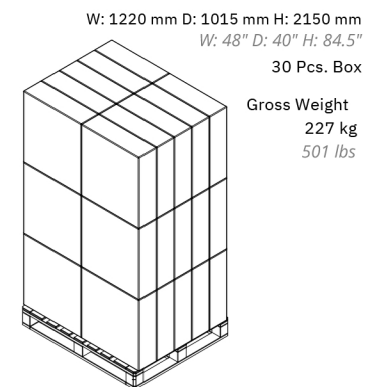

### ACOUSTIC PERFORMANCE

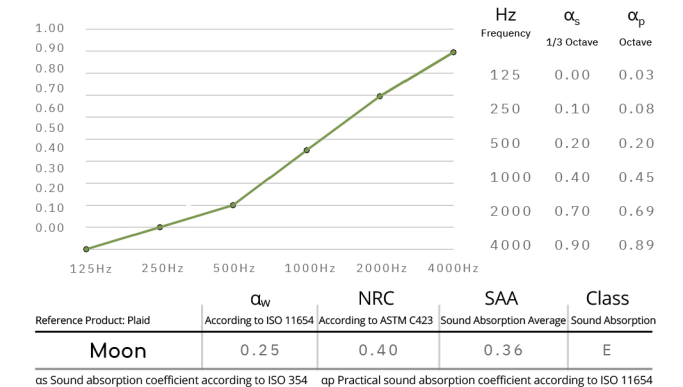





# Saturn

600mm x 600mm x 13mm

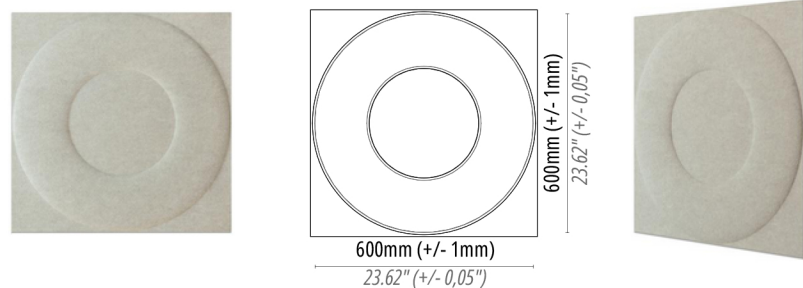

		Inherent Colors	Color-IT Colors	Peel & Stick (Optional)
<b>PRODUCT CODE / DESCRIPTION</b>	<b>Box Qty /m2</b>			
STN-20AAN - Inherent Colors (Panel Only)	12 / 4.32 m2			
STN-20PSN - Inherent Colors + Peel & Stick	12 / 4.32 m2			
STN-20AAC - Color-IT (Panel Only)	12 / 4.32 m2			
STN-20PSC - Color-IT + Peel & Stick	12 / 4.32 m2			

**APPLICATION**  
Wall & Ceiling - Indoor use only

**MATERIAL**  
Mechanical needled punch industrial felt.  
100% PET up to 60% Recycled content & Recyclable

Smooth Surface - Impact Resistance - Flexible

**FIRE RATING**  
A Class (ASTM E84) - B s1 d0 (EN 13501-1)

**THERMAL INSULATION**  
0,035 W/mK

**WEIGHT**  
1 tile: 450 gr. +/- 10% tolerance  
1 tile: 1 lb with +/- 10% tolerance

**THICKNESS**

Max. 13 mm (+/- 2 mm) - 0.51" (+/-0.08")  
Min. 3 mm (+/- 2 mm) - 0.12" (+/-0.08")

**BOX SIZE & CONTENT**  
W: 620 mm D: 660 mm H: 190 mm  
W: 24.5" D: 26" H: 7.5"  
1 Box: 12 x panels  
1 Box: 4.32 m2 1 Box: 46.50 ft2  
1 Color of choice per package  
Gross weight: 6.8 kg Gross weight: 15 lbs



## PALETTE SIZE & CONTENT

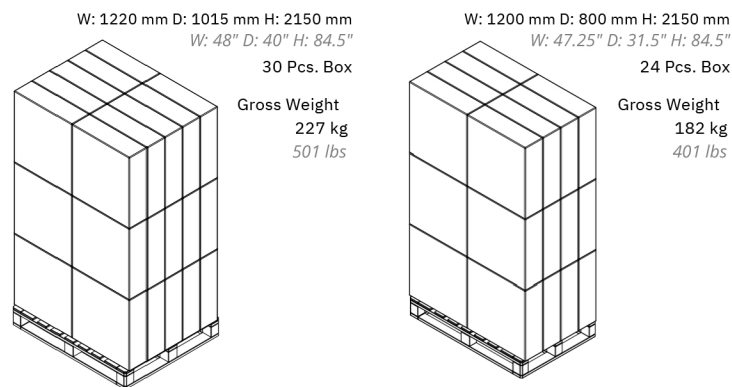

## ACOUSTIC PERFORMANCE

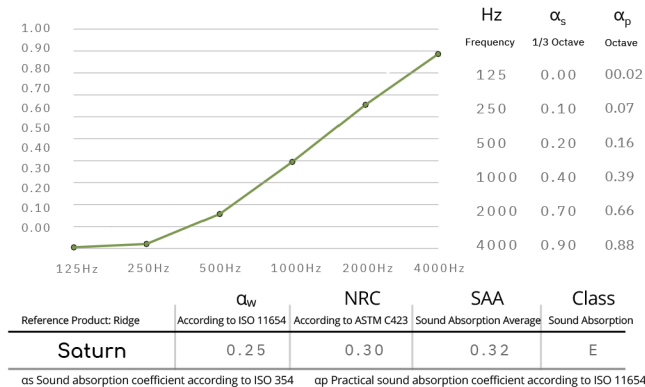

# Venus

600mm x 600mm x 13mm

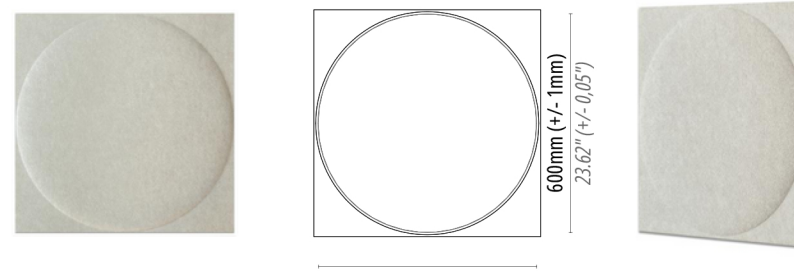

		Inherent Colors	Color-IT Colors	Peel & Stick (Optional)
<b>PRODUCT CODE / DESCRIPTION</b>	<b>Box Qty /m2</b>			
VNS-20AAN - Inherent Colors (Panel Only)	12 / 4.32 m2			
VNS-20PSN - Inherent Colors + Peel & Stick	12 / 4.32 m2			
VNS-20AAC - Color-IT (Panel Only)	12 / 4.32 m2			
VNS-20PSC - Color-IT + Peel & Stick	12 / 4.32 m2			

**APPLICATION**  
Wall & Ceiling - Indoor use only

**MATERIAL**  
Mechanical needled punch industrial felt.  
100% PET up to 60% Recycled content & Recyclable

Smooth Surface - Impact Resistance - Flexible

**FIRE RATING**  
A Class (ASTM E84) - B s1 d0 (EN 13501-1)

**THERMAL INSULATION**  
0,035 W/mK

**WEIGHT**  
1 tile: 450 gr. +/- 10% tolerance  
1 tile: 1 lb with +/- 10% tolerance

**THICKNESS**

Max. 13 mm (+/- 2 mm) - 0.51" (+/-0.08")  
Min. 3 mm (+/- 2 mm) - 0.12" (+/-0.08")

**BOX SIZE & CONTENT**  
W: 620 mm D: 660 mm H: 190 mm  
W: 24.5" D: 26" H: 7.5"  
1 Box: 12 x panels  
1 Box: 4.32 m2 1 Box: 46.50 ft2  
1 Color of choice per package  
Gross weight: 6.8 kg Gross weight: 15 lbs



## PALETTE SIZE & CONTENT

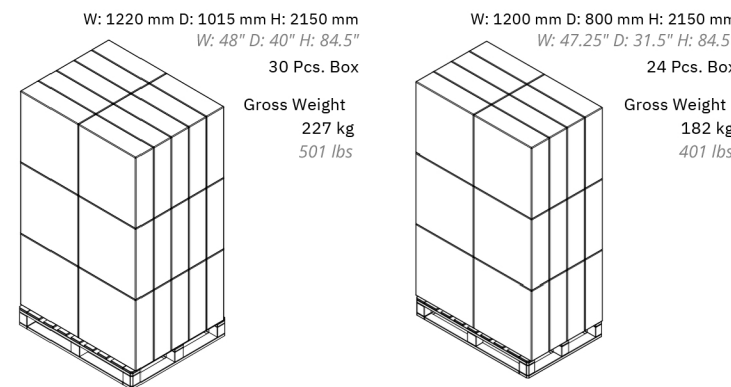

## ACOUSTIC PERFORMANCE

